

BS60

Basic pedestal

January 2025

DESCRIPTION:

BS60 Series Modules are suitable to create raised floors from tiles and pavers. In compliance with this type of flooring can be used with natural stone, ceramic and composite materials.



FEATURES:

Raw material	Polypropylene
Height range	Adjustable min.32 mm - max. 250 mm
Base diameter	187 mm
Base wall thickness	3 mm
Head diameter	116 mm
Laying surface of base	302 cm ²
Tab thickness	2 mm/3 mm/4 mm (removable)
Tab height	10 mm
Slope correction	% 5
Environmental impact assessment	Eco friendly

APPLICATION AREAS:

Can be used for all indoor and outdoor areas. Also, on levelled surfaces, epoxy or membrane insulated areas.

APPLICATION:

Use of any fixing material is not necessary. Optionally, the modules can be fixed to the application surface using adhesive or screw.

RAW MATERIAL:

Carrier	Polypropylene
Product code	240 KTPH
Product colour	Black
Filler	Calcium carbonate (CaCO ₃)



BS60 TECHNICAL DRAWING:

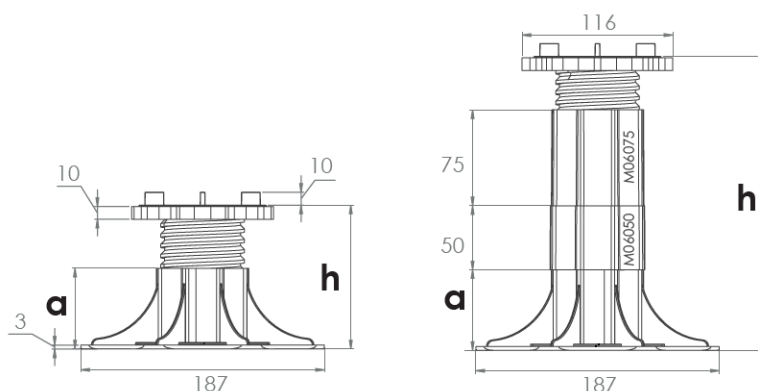
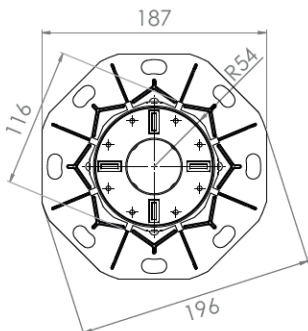

4131EF Equus Fixplus Deck & Tile Support System

Equus Industries Ltd. 4 Sheffield St, Blenheim 7274 | Phone: 03 578 0214 | Email: info@equus.nz | Web: www.equus.nz

The information in this product data sheet is based on our experience and testing. It represents the latest information available at the time of printing, but no guarantee of its accuracy is made or implied, nor responsibility taken for use to which this information may be put. We reserve the right to alter or up-date information parameters and formulations at any time without notice.

BS60

Basic pedestal

January 2025

BS60 DIMENSION AND WEIGHT:

Model	BS60-01	BS60-02	BS60-03	BS60-04	BS60-05	BS60-06	BS60-07	BS60-08	BS60-09	BS60-10
a	18 mm	27 mm	40 mm	62 mm	40 mm	62 mm	62 mm	62 mm	62 mm	62 mm
h (min. - max)	32-38 mm	38-50 mm	50-75 mm	73-110 mm	102-130 mm	126-155 mm	147-184 mm	175-205 mm	200-225 mm	220-250 mm
Extension	-	-	-	-	M06050	M06050	M06075	M06050	M06050 M06075	M06075
Weight	0,170 kg	0,180 kg	0,198 kg	0,230 kg	-	-	-	-	-	-
Comp.					 +	 +	 +	 +	 +	 +

Note: BS60-06-07-08-09-10 is constituted of BS60-04 body and screw.

BS60-05 is constituted of BS60-03 body and screw.

BS60 PRESSURE RESISTANCE:

Pressure measuring point

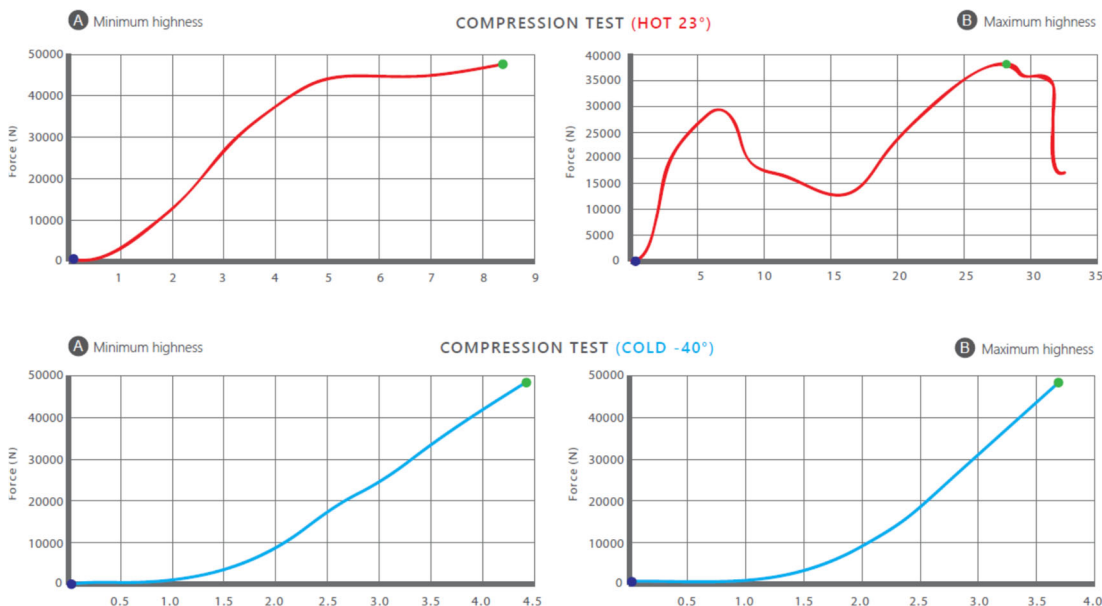
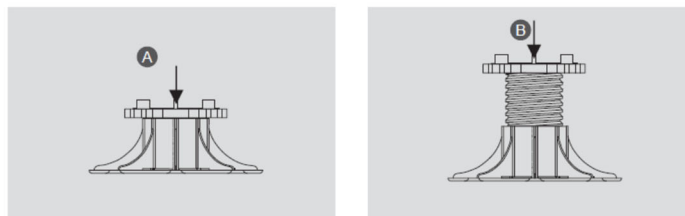

TESTED AND APPROVED BY HEADSHIP OF TURKISH STANDARDS INSTITUTION (TSE) AND CALIBRATION CENTER CONSTRUCTION MATERIALS LABORATORY (ANKARA CITY)

BS60

Basic pedestal

January 2025

BS60 PACKAGING INFORMATION:

Product code	BS60-01	BS60-02	BS60-03	BS60-04	M06050	M06075
Pcs per box	80*	70*	50*	40*	60***	40***
Gross weight per box	13,30 kg	13,20 kg	11,22 kg	10,56 kg	5,40 kg	4,00 kg
Boxes per pallet	12	12	12	12	48	48
Box dimensions	* 60cm x 40cm x h=40cm		** 40cm x 30cm x h=41cm		*** 40cm x 30cm x h=20cm	
Gross weight per pallet	185 kg	184 kg	160 kg	152 kg	285 kg	217 kg
Pallet dimensions	cm 80 x 120 x h140					

- Products are packed in cardboard boxes. Shrink-wrapped euro-pallets are used for final packaging. In spite of being shrink-wrapped and rain proof packaging, it is recommended to keep the pallets in a closed area.
- The technical data products above indicate the current production. It may be updated or modified at any time without prior notice.
- We do not take any responsibility for any problem caused by misuse of the products.

WARNINGS AND BANS:

Is the building product/building product line subject to warning or ban under section 26 of the Building Act 2004?	No
--	----

MANUFACTURERS CONTACT DETAILS:

Manufacture location	Turkey
Legal and trading name of manufacturer	Ozturk Plastic Kalip San. Tic. Ltd. Sti.
Manufacturer address for service	Ikitelli Org.San.Bol. Mah. Enkoop Cad. No:4/C Blok Basaksehir / Istanbul
Manufacturer website	Www.fixplus.com.tr
Manufacturer email	orders@tremco.com.au
Manufacturer phone number	+90 212 485 24 53