



SINTEF Building and Infrastructure
P.O.Box 124 Blindern
NO-0314 Oslo, Norway
Phone +47 73 59 30 00
e-mail: certification@sintef.no



Member of



www.eota.eu

European Technical Assessment

ETA-08/0285
of 12.05.2017

General Part

Technical Assessment Body issuing the ETA:
SINTEF Building and Infrastructure

Trade name of the construction product	Guardian Fastening System
Product family to which the construction product belongs	Fasteners for mechanically fastened flexible roof waterproofing systems
Manufacturer	AFAST Holding BV Grasbeemd 14 5705 DG Helmond The Netherlands
Manufacturing plant(s)	AFAST Holding BV Grasbeemd 14 5705 DG Helmond The Netherlands
This European Technical Assessment contains	23 pages including 2 Annexes which form an integral part of this assessment
This European Technical Assessment is issued in accordance with regulation (EU) No 305/2011, on the basis of This version replaces	ETAG 006 used EAD 2012 ETA-08/0285 issued on 07.03.2014

Specific parts

For the **Specific Parts** of the ETA please see Regulation (EU) No 1062/2013 at

<http://eur-lex.europa.eu/legal-content/EN/TXT/?qid=1500532911238&uri=CELEX:32013R1062>

1. Technical description of the product

Guardian Fastening System is used as mechanical fastening of insulation, bitumen based single/multi-layer or single ply waterproofing membranes, or polymeric single ply waterproofing membranes, for flat roofing. The supporting roof structure may be of profiled steel sheets, concrete, light weight concrete or wood as defined in ETA Guideline No. 006 edition March 2000, amended November 2012. For Systems of mechanically fastened flexible roof waterproofing membranes, paragraph 2.2 iii.

The range of fasteners consists of washers, washers with integrated sleeve, screws, nails, and plugs as illustrated in Annex 1. Guardian Fastening System also consists of GuardianWeld & Centrix electro bonding system which is used to bond special adhesive coated metal fixing plates to single-ply waterproofing membranes.

The fastener system is introduced to the market separately from the other components of roof waterproofing membrane kits, and this ETA covers only the performance characteristics of the Guardian Fastening System. A separate ETA according to ETAG 006 is necessary in order to cover an entire kit for mechanically fastened roof waterproofing membranes.

The fasteners may be used for all types of flexible membranes. The supporting roof structure may consist of profiled steel sheets, concrete, light weight concrete, or a wood based construction. The Guardian Fastening System may be used with membranes installed on a thermal insulation material or directly to the supporting roof deck.

2. Specification of the intended use in accordance with the applicable European Assessment Document (hereinafter EAD)

General

The fasteners must be installed according to the manufacturer's instructions. It is the manufacturer's responsibility to provide correct information about the application of the products to the users.

Fastening with steel washers may on stiff substrates, i.e. on wood-based roof substrate, non-compressible insulation or on concrete.

Plastic fasteners with integrated sleeve or step secured steel washers (steel washers together with screws equipped with a separate threading which avoid the washer to be pressed down) are recommended on thermal insulation.

If there is doubt about the suitability of the substrate, e.g. on a construction site, a pull-out test on site should be performed to verify the performance of the fastener (see ETAG 006 Annex C). Furthermore, care should be taken during design to ensure that galvanic corrosion between metal parts, especially between substrate and screw, does not occur. Likewise, use of insulation materials containing substances which can affect the performance of the fasteners must be avoided.

Fastening in wood

Minimum thickness for timber based substrate is 18 mm. For timber deck applications a site pull out test is recommended.

Fastening in concrete

When fixing Guardian concrete nails and screws the drill hole diameter must be normally 5 mm. The drill hole depth should be normally minimum 30 mm, unless special precautions are taken regarding installation control and inspection. Minimum anchorage depth shall be normally minimum 20 mm. Fixings in 40 mm thick concrete without penetration requires drilling with depth control. Concrete compression strength is minimum class C25/30 according to EN 206-1.

Fastening in light weight concrete

When fixing Guardian Light Weight Concrete Screw LBS 8.0 and LBS 6.0 in aerated concrete, the anchoring depth must be normally minimum 65 mm. Pull-out tests are always recommended in light weight concrete. The LBS 6.0 screw can also be used in lower quality concrete less than C25/30 according to EN 206-1 with a minimum anchoring depth of 40mm and drill hole diameter of 5 mm.

Fastening in steel sheets

Load bearing decks made of profiled steel sheets normally have a minimum thickness of 0.7 mm and quality S280. Using Guardian steel sheet fasteners in profiled steel sheets, the anchoring depth must be minimum 20 mm. In annex 2 table 4 the axial load resistance of every steel sheet fastener is listed.

Fastening with GuardianWeld & Centrix-system

The GuardianWeld & Centrix electro bonding system must be applied according to the manufacturer's user manual. The different types of plates are laminated with special heat activated adhesive for PVC, TPO or EPDM waterproofing membranes.

3. Performance of the product and references to the methods used for its assessment

See Annex 2.

4. Assessment and verification of constancy of performance (hereinafter AVCP) system applied, with reference to its legal base

Mechanical resistance and stability

Not relevant.

Safety in case of fire

No performance determined. The reaction to fire of roof waterproofing kits is determined for the complete kits including the membrane.

Hygiene, health and environment

According to the manufacturer's declaration the screws and washers with corrosion protection contains no chromium 6 compounds. Consequently the products do not contain any dangerous substances according to the EU database.

Safety in use

The fasteners have been tested for wind uplift according to EN-16002:2010 / ETA Guideline No. 006 edition March 2000, amended November 2012. For Systems of mechanically fastened flexible roof waterproofing membranes, paragraph 2.2 iii. Axial pull out performance from substrates and resistance to unwinding are shown in Annex 2. The wind uplift performance of roof waterproofing kits is mainly determined by the roofing membranes. More than 180 full scale wind load tests with bituminous and polymeric membranes have been executed. The membranes are fixed with washers, washers with integrated sleeves and barbed washers in combination with fixings to substrates of steel sheets, wood, concrete and light weight concrete. The complete test reports may be obtained from AFAST Holding BV.

Protection against noise

Not relevant

Energy consumption and heat retention

Not relevant

Aspects of durability

The plastic fasteners produced of polypropylene and polyamide satisfy the aspects of durability according to ETAG 006 ch. 5.3.7, see Annex 2. The Guardian tube washers made of polypropylene and polyamide have an acceptable resistance to brittleness according to ETAG 006 ch. 5.3.4, see Annex 2.

Carbon steel fasteners have a corrosion protection of Chrome 6 free Enduroguard 15[®] or Durocoat[®] coating. Stainless steel fasteners in grade SS304/A2 or SS316/A4. All metallic components in the Guardian fastening system correspond to corrosion protection according to ETAG 006 ch.5.3.7, see Annex 2. Test procedure is 15 cycles Kesternich (2l SO₂).

Identification

The characteristic values of detailed product dimensions and respective tolerances are stated in the manufacturer's technical dossier and form a part of the control plan for the factory production control. All fasteners, steel washers and tube washers are either marked with the Guardian "G" mark or brand name "Guardian". The marking of tube washers may be combined with the Guardian Type or another brand name for products produced under private label. All packaging is to be marked with product type and batch number, including CE marking.

5. Technical details necessary for the implementation of the AVCP system, as provided for in the applicable EAD

According to Decision 98/143/EC by the European Commission, the system 2+ of assessment and verification of constancy of performance applies. See Annex V to Regulation (EU) No. 305/2011.

Issued in Trondheim on 12.05.2017

By

SINTEF Building and Infrastructure



Hans Boye Skogstad
Approval Manager

Annex 1

Description of Guardian Fastening System

Table 1

Fastener type	Fig. no	Function	Material
GUARDIAN R 45 & HR 45	1	Tube washer	Polypropylene
GUARDIAN RB 48	2	Tube washer with three barbs	Polypropylene
GUARDIAN RBS 50	3	Tube washer with six barbs	Polypropylene
GUARDIAN TBPA 8040 GUARDIAN TBPP 8040	4	Tube washer with two barbs	Polyamide 6.6 Polypropylene
GUARDIAN R 75 & HR 75	5	Tube washer	Polypropylene
GUARDIAN PP 45	6	Washer with ten barbs	Polyamide 6.0
GUARDIAN SP 40-D, F, DD, FD	7	Steel washer	Galvanized steel
GUARDIAN SP 40-LBS	8	Steel washer	Galvanized steel
GUARDIAN SP 50-D,F,S	9	Steel washer	Galvanized steel
GUARDIAN SPB 50-S	10	Barbed steel washer	Galvanized steel
GUARDIAN SP 8240-D, F, S GUARDIAN SPA 8240-D,F	11	Steel washer	Galvanized steel
GUARDIAN SPB 8240-D GUARDIAN SPBA 8240-D	12	Barbed steel washer	Galvanized steel
GUARDIAN SP 70-D,F,S, CP	13	Steel washer	Galvanized steel
GUARDIAN STBS GUARDIAN STBT GUARDIAN STBST	14	Steel bar	Galvanized steel
GUARDIAN GWSP(P,T,E)-80-F4E GUARDIAN GWSP(P,T,E)-80-F2E	15	Steel washer	Galvanized steel + Coated & laminated
GUARDIAN GWT & GWT ASTL GUARDIAN CT & CT ASTL	16	Tube washer for combination with steel washers/bars	Polyamide 6.0 Polypropylene
GUARDIANWELD INDUCTION MACHINE*	17	Machine for welding GWSP(P,T,E)-80-F2E/F4E	
GUARDIAN BN 5.6	18	Concrete nail	Coated carbon steel
GUARDIAN BNRF 5.5	19	Concrete nail	Stainless steel
GUARDIAN CS 6.1	20	Concrete screw	Coated carbon steel
GUARDIAN ACS-6.1	21	Concrete screw with hexagonal nut	Coated carbon steel
GUARDIAN CP-8 & CPN-8	22	Concrete plug	Coated steel pin/ Polypropylene
GUARDIAN LBS 6.0	23	Light weight concrete/wood screw	Coated carbon steel
GUARDIAN LBS 8.0	24	Light weight concrete screw	Coated carbon steel
GUARDIAN HD 6.1	25	Concrete/light weight concrete/wood screw	Coated carbon steel
GUARDIAN PS 4.8	26	Steel sheet screw	Coated carbon steel
GUARDIAN BS 4.8	27	Steel sheet screw	Coated carbon steel
GUARDIAN BSHD 4.8	28	Steel sheet screw	Coated carbon steel
GUARDIAN BSRF 4.8	29	Steel sheet screw	Stainless steel
GUARDIAN DBT(A) 4.8	30	Steel sheet screw	Coated carbon steel
GUARDIAN DB(A) 4.8	31	Steel sheet screw	Coated carbon steel
GUARDIAN DBT(A) S 4.8	32	Steel sheet screw	Stainless steel
GUARDIAN BS 5.5	33	Steel sheet screw	Coated carbon steel
GUARDIAN BS 6.1	34	Steel sheet screw	Coated carbon steel
GUARDIAN BS 6.8	35	Steel sheet screw	Coated carbon steel
GUARDIAN GPR 6.3	36	Peel Rivet	Aluminium body/Galvanized Pin
GUARDIAN TS 5.2	37	Timber deck screw	Coated carbon steel
GUARDIAN MTS 4.8	38	Timber deck screw	Coated carbon steel
GUARDIAN LBS 6.0	39	Light weight concrete/wood screw	Coated carbon steel
GUARDIAN HD 6.1	40	Concrete/light weight concr./wood screw	Coated carbon steel

*The GUARDIANWELD induction machine is not assessed by SINTEF

Guardian Tubes

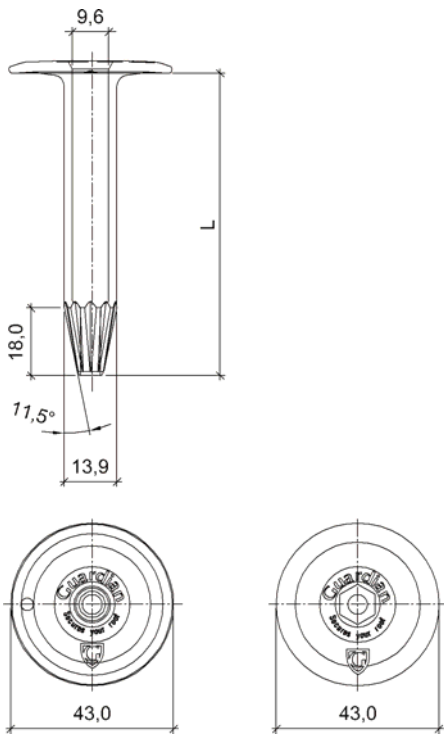

Fig.1
 Tube washer R(P) 45
 Tube washer HR45 with hexagonal internal tube shape (used together with ACS 6.1).

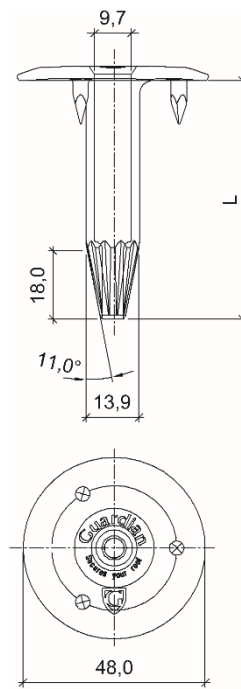

Fig. 2
 Tube washer RB 48 with three bars

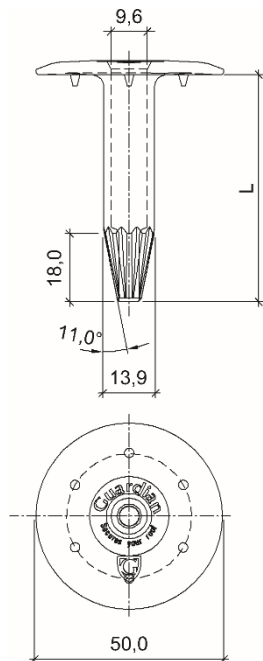

Fig. 3
 Tube washer RBS 50 with six bars

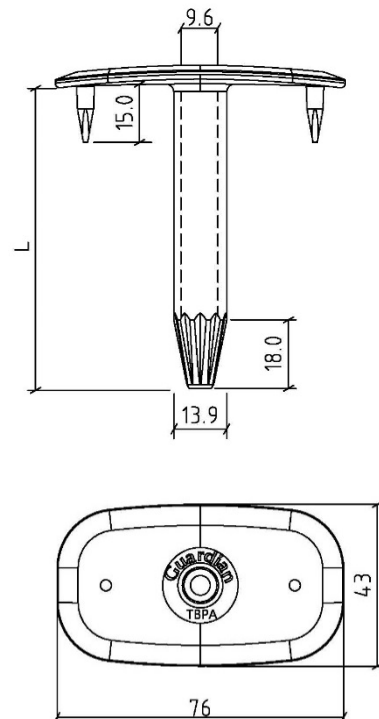

Fig. 4
 Tube washer TBPA-8040 with two bars (Polyamide)
 Tube washer TBPP-8040 with two bars (Polypropylene)

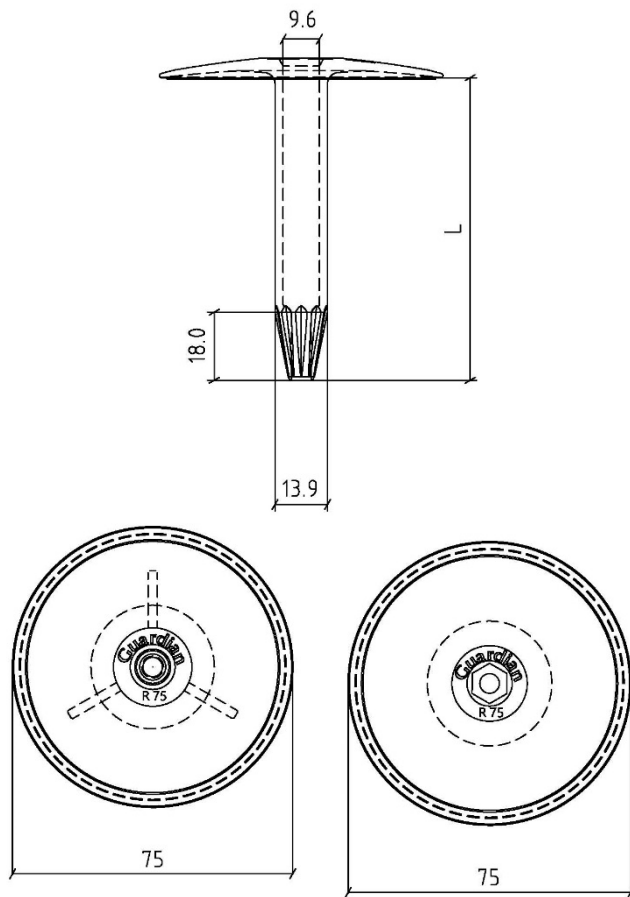

Fig. 5
 Tube washer R-75
 Tube washer HR-75 with hexagonal internal tube shape (used together with ACS 6.1)

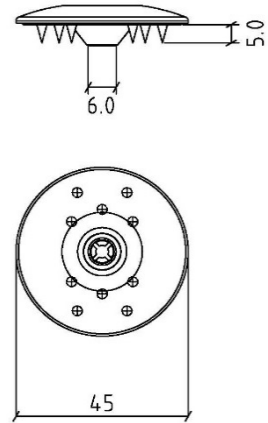

Fig. 6
 Tube washer PP-45 with ten barbs for fixation of synthetic membranes

Guardian steel pressure plates

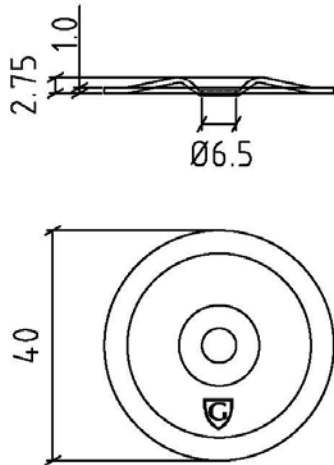

Fig. 7
SP-40-D, F, DD, FD

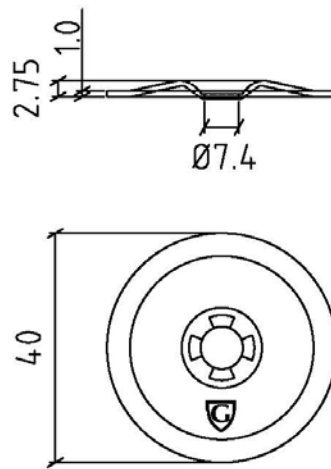

Fig. 8
SP-40-LBS

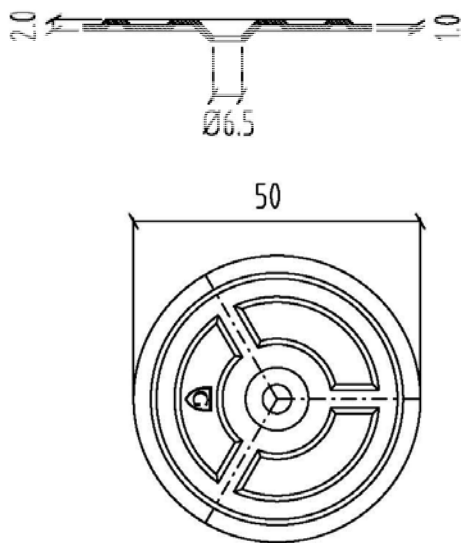

Fig. 9
SP-50-D, F, S

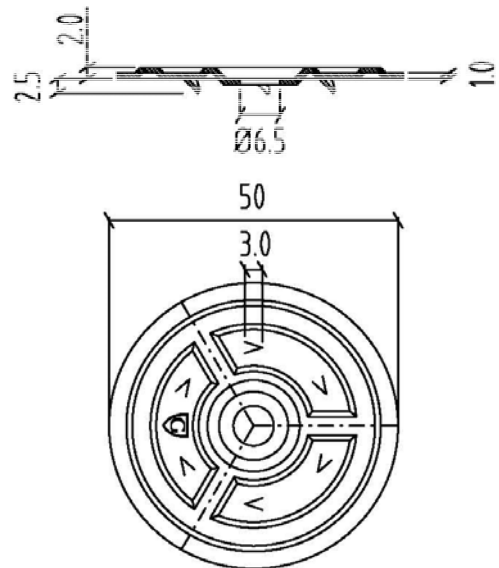
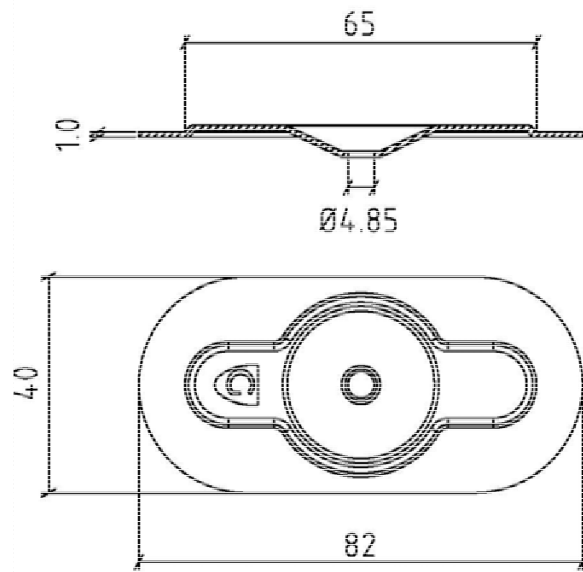

Fig. 10
SPB-50-S



SP-8240-D,F,S
SPA-8240-D, F

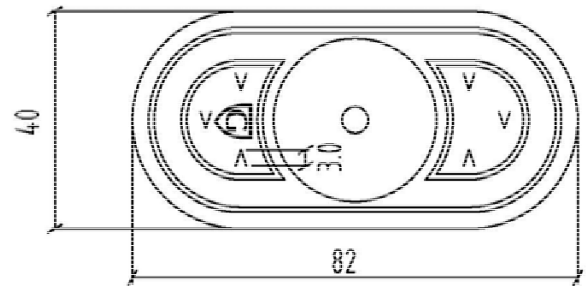
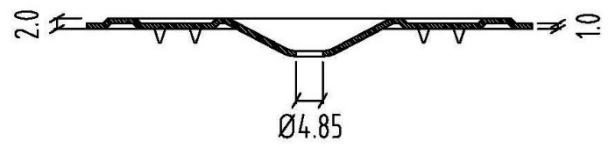

Fig. 12
SPB-8240-D
SPBA-8240-D

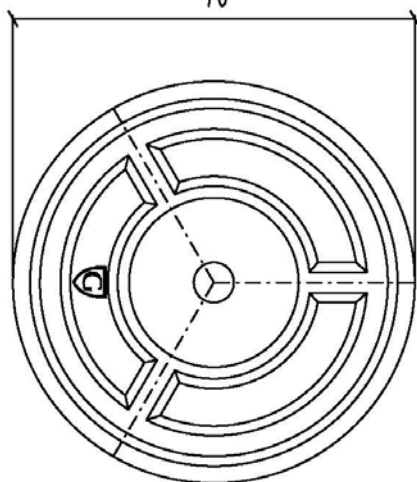
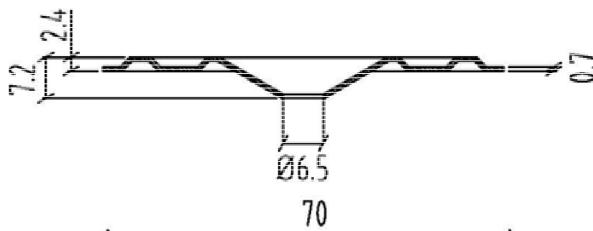

Fig. 13
SP-70-D, F, S, CP

Guardian steel bar

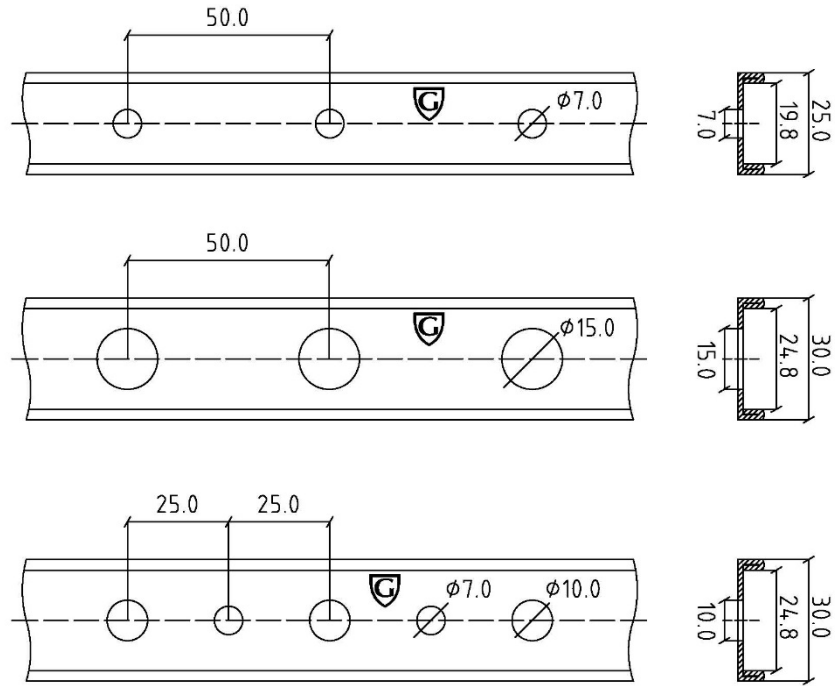

Fig. 14
 STBS Steel bar with small holes and a thickness of 1.25mm
 STBT Steel bar with big holes (usable with CT tube fig. 15) and a thickness of 1.25mm
 STBST Steel bar with small and big holes and a thickness of 1.25mm

GuardianWeld induction system

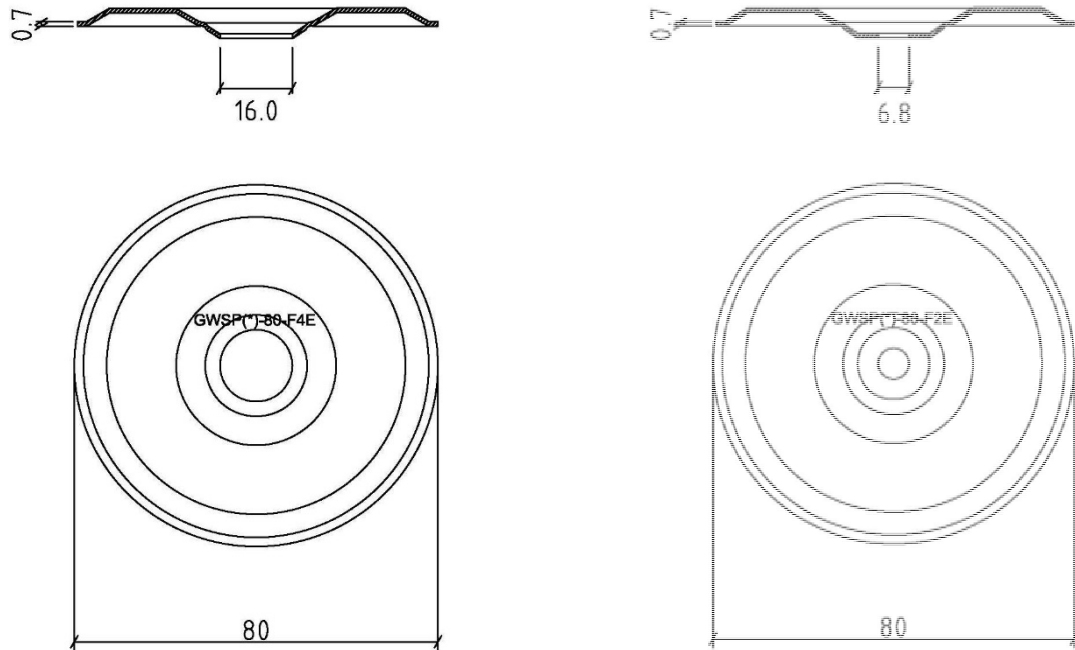

Fig. 15
 GWSP(P,T,E)-80-F4E (usable with GWT fig. 16)
 GWSP(P,T,E)-80-F2E

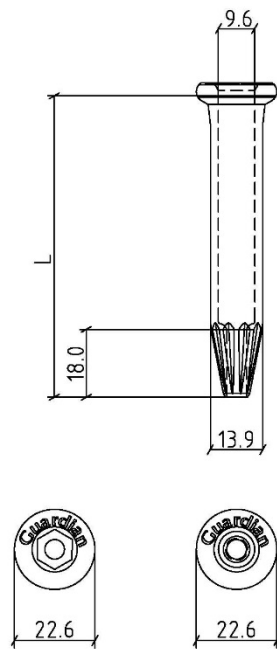

Fig. 16
 GWT tube for GWSP(*)-80-F4E (Polyamide)
 CT tube for STBT (Polypropylene)



Fig. 17
 GuardianWeld induction machine
 Welds the GWSP(*)-80-F2E/F4E to PVC, TPO and EPDM membranes

Guardian Fasteners for concrete

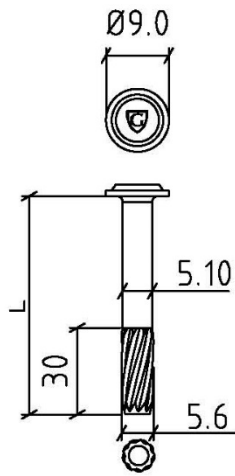

Fig. 18
BN 5.6 Concrete nail

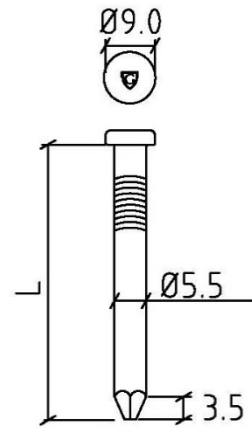

Fig. 19
BNRF 5.5 Stainless concrete nail

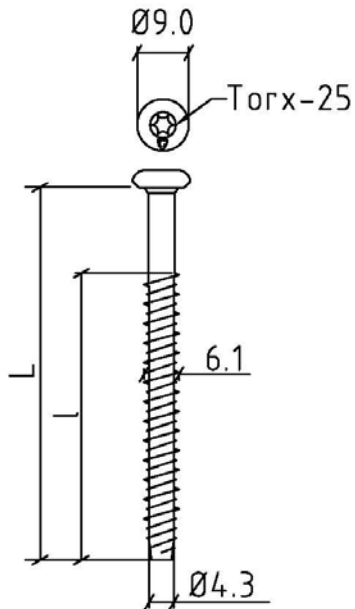

Fig. 20
CS 6.1 Concrete screw
(with flat or sharp point)

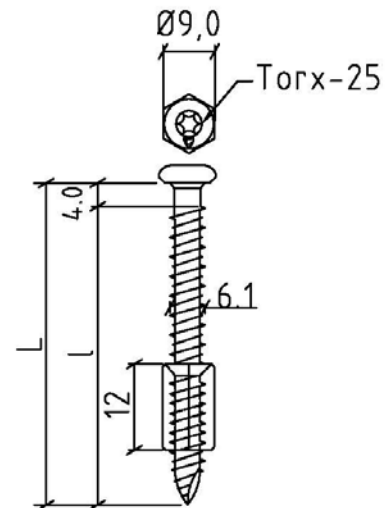

Fig. 21
ACS 6.1 Adjustable concrete screw
(used together with tube washer HR versions)

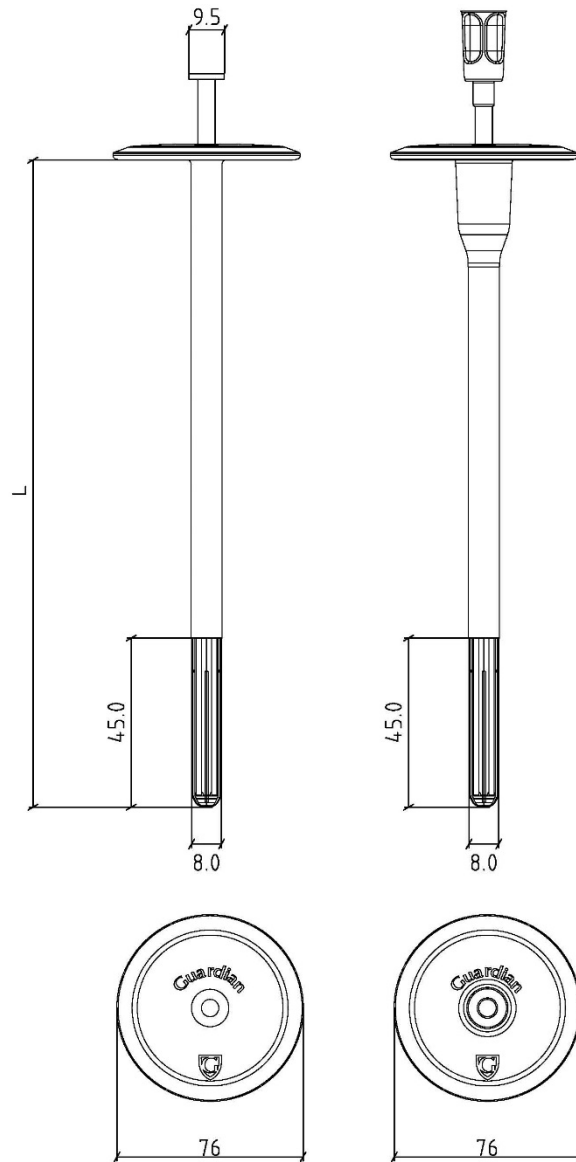

Fig. 22
 CPN-8 Concrete plug
 CP-8 Concrete plug with energy bridge stop (also usable with SP-70-CP)

Guardian Fasteners for lightweight concrete

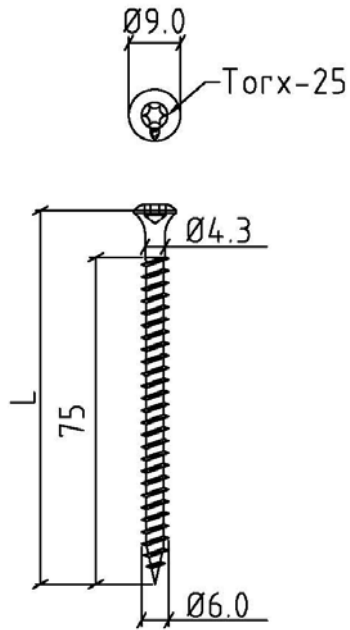

Fig. 23
LBS 6.0 screw for lightweight concrete, concrete and wooden substrates

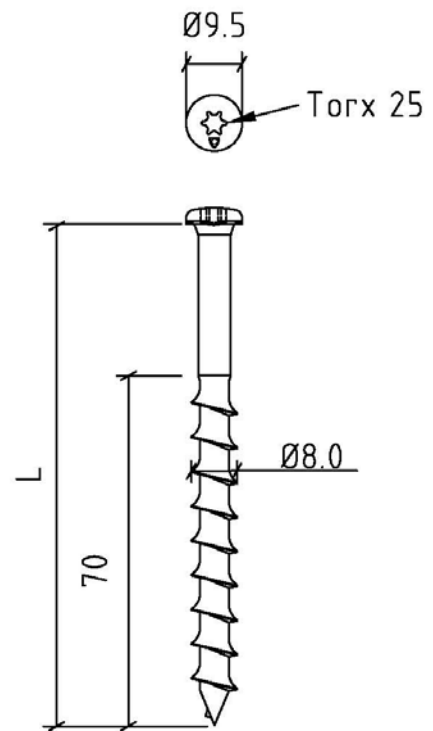

Fig. 24
LBS 8.0 screw for lightweight concrete

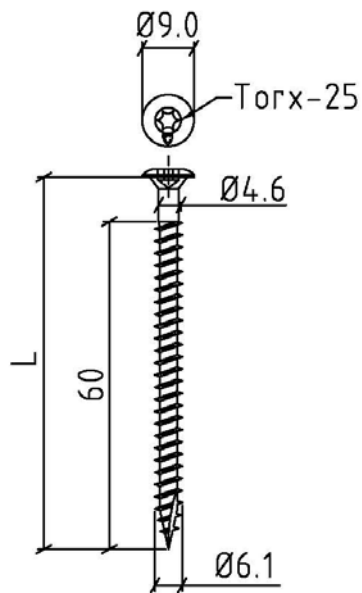

Fig. 25
HD 6.1 Screw for lightweight concrete, concrete and wooden substrates

Guardian Fasteners for profiled steel sheets substrate

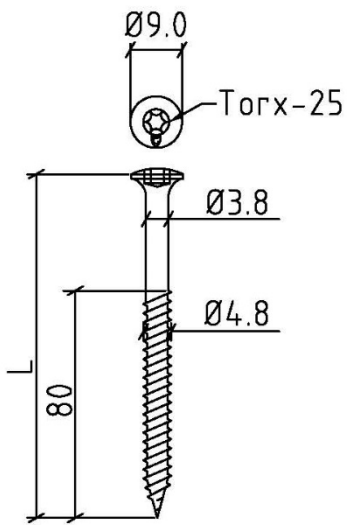

Fig. 26
PS 4.8 Screw for fixing in steel sheets

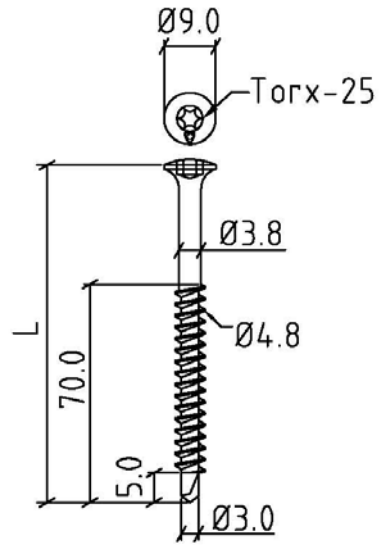

Fig. 27
BS 4.8 Screw for fixing in steel sheets

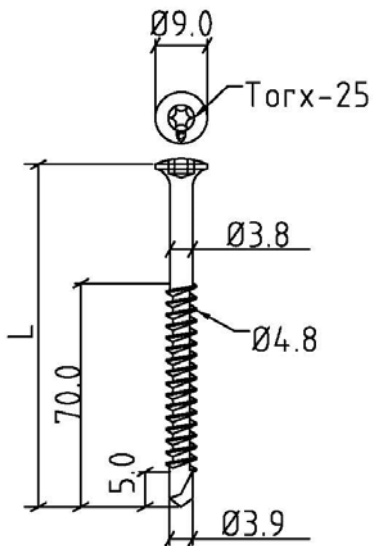

Fig. 28
BSHD 4.8 Screw for fixing in steel sheets
(steel thickness from 1,0mm up to maximum 3,0mm)

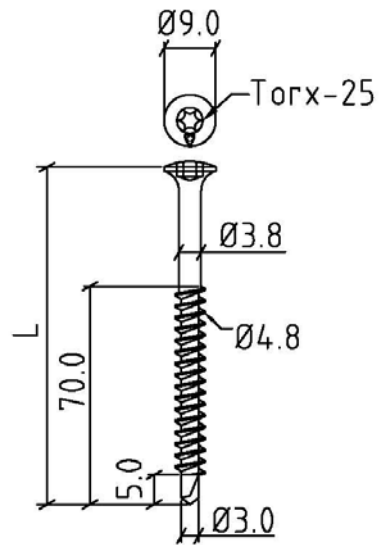

Fig. 29
BSRF 4.8 Stainless screw for fixing in steel sheets

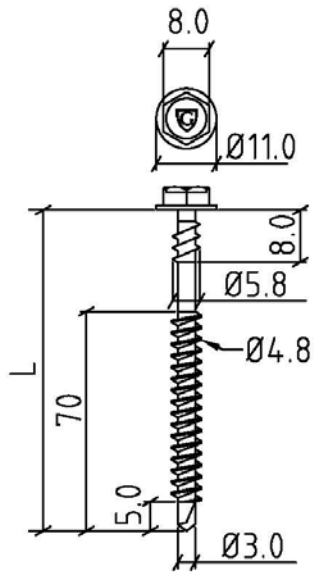

Fig. 30
DBT(A) 4.8 Screw for fixing in steel sheets
(usable with automatic setting tool)

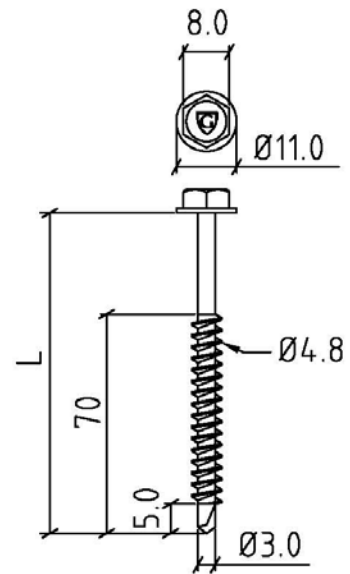

Fig. 31
DB(A) 4.8 Screw for fixing in steel sheets
(usable with automatic setting tool)

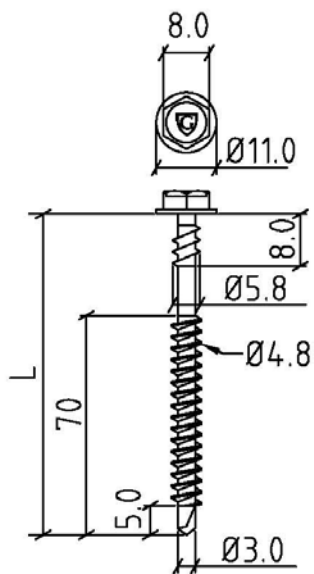

Fig. 32
DBT(A)-S 4.8 Stainless-steel A4 screw for fixing in steel sheets
(usable with automatic setting tool)

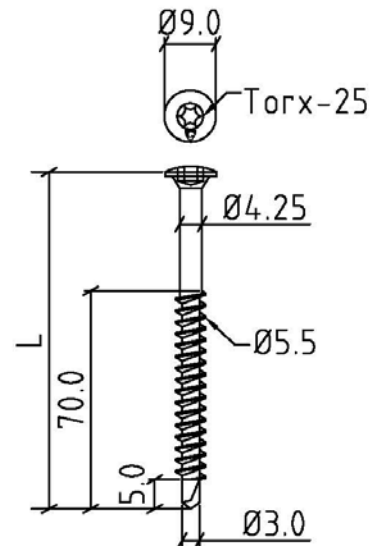

Fig. 33
BS 5.5 Screw for fixing in steel sheets

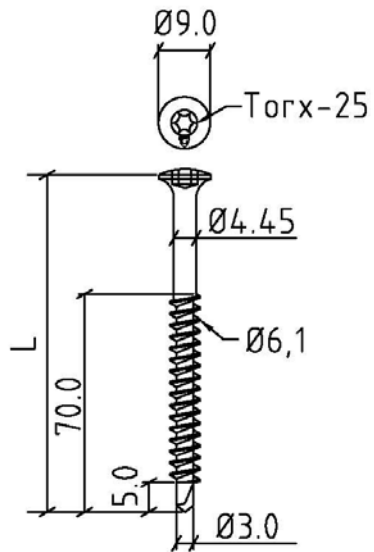

Fig. 34
BS 6.1 Screw for fixing in steel sheets

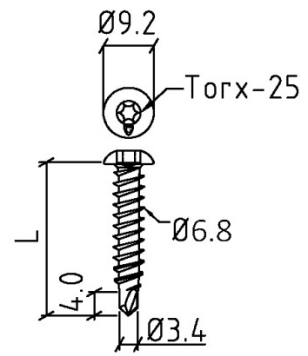

Fig. 35
BS 6.8 Screw for fixing in thin steel sheets

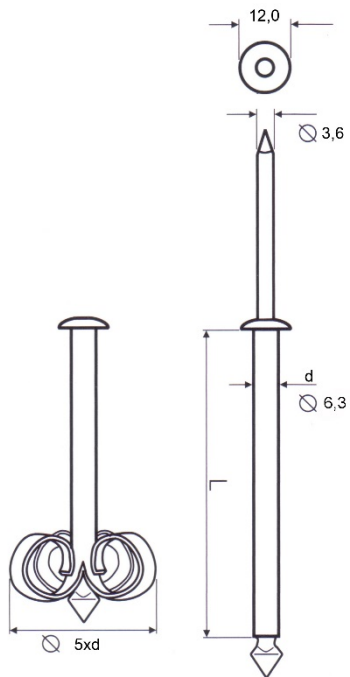

Fig. 36
GPR 6.3 Peel Rivet

Guardian Fasteners for wooden substrates

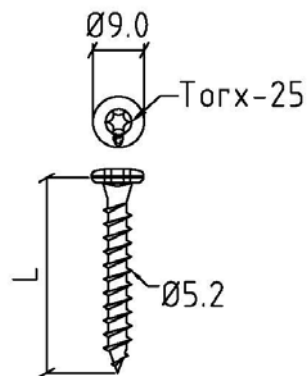

Fig. 37
TS 5.2 Screw for fixing in wood

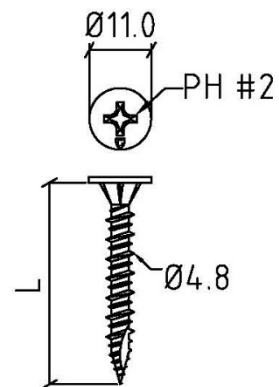

Fig. 38
MTS 4.8 screw for fastening metal to timber constructions

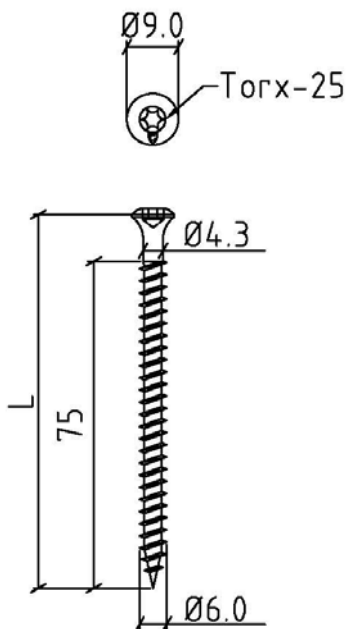

Fig. 39
LBS 6.0 Screw for light weight concrete, concrete and wooden substrates

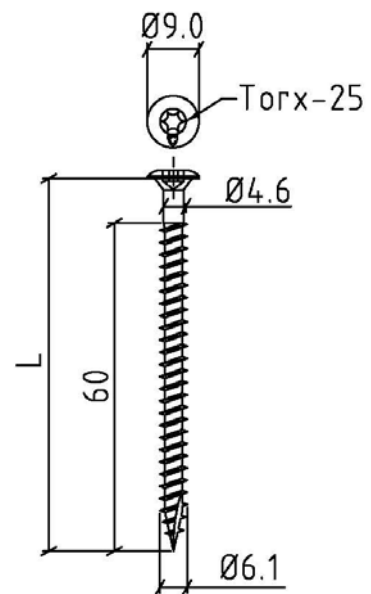

Fig. 40
HD 6.1 Screw for light weight concrete, concrete and wooden substrates

Performance of Guardian Fastening system on different substrates

Characteristic values are calculated from the following formula:

$$W_{char} = \alpha (X_m - (k \times s))$$

where: W_{char} = characteristic y values of axial load resistance

α = corr. factor for tested substrate spec. compared with nominal substrate spec.

X_m = mean axial pull-out load for 10 specimens

$k = 1,92$ (according to Table D1 in EN-1990:2002)

s = standard deviation

Table 2: Concrete substrate ¹⁾

Fastener	Substrate	Washer	Characteristic values of axial load resistance (kN)
GUARDIAN CS 6.1 / ACS-6.1	C25-C30	SP 50	4,28
GUARDIAN BNRF 5.5	C25-C30	SP-50	1,79
GUARDIAN BN 5.6	C25-C30	SP 50	1,92
GUARDIAN CP & CPN (Polypropylene)	C25-C30	-	1,57
GUARDIAN HD 6.1	C25-C30	SP 50	4,83
GUARDIAN LBS 6.0	C20-C25	SP 50	2,92
GUARDIAN LBS 6.0	C25-C30	SP 50	3,26

¹⁾ See clause 2 regarding hole diameter and drill depth

Table 3: Light weight concrete substrate ²⁾

Fastener	Substrate	Washer	Characteristic values of axial load resistance (kN)
GUARDIAN LBS 6.0	YtongTM Density 600 kg/m ³	SP 50	2,07
GUARDIAN LBS 8.0	Density 450 kg/m ³	SP-40-LBS	0,93
GUARDIAN LBS 8.0	Density 550 kg/m ³	SP-40-LBS	1,44
GUARDIAN HD 6.1	Density 600 kg/m ³	SP 50	1,36

²⁾ Autoclaved aerated concrete units according to EN 771-4

Table 4: Profiled steel sheets substrate ³⁾

Fastener	Substrate	Washer ⁵⁾	Characteristic values of axial load resistance (kN)	Durability Resistance to unwinding ETAG 006 cl. 5.3.7 D.2.3, D.3.1, D.3.2 and cl. 5.3.4 D.2.2
GUARDIAN PS 4.8	Steel sheet 0,70mm	SP 50	1,31	Approved
GUARDIAN PS 4.8	Steel sheet 0,75mm	SP 50	1,52	Approved
GUARDIAN PS 4.8	Steel sheet 1,00mm	SP 50	1,94	Approved
GUARDIAN BS 4.8	Steel sheet 0,70mm	SP 50	1,17	Approved
GUARDIAN BS 4.8	Steel sheet 0,75mm	SP 50	1,45	Approved
GUARDIAN BS 4.8	Steel sheet 0,80mm	SP 50	1,54	Approved
GUARDIAN BSHD 4.8	Steel sheet 1,00mm	SP 50	1,65	Approved
GUARDIAN BSHD 4.8	Steel sheet 1,25mm	SP 50	2,10	Approved
GUARDIAN BSRF 4.8	Steel sheet ,75mm ⁴⁾	SP 50	1,02	Approved
GUARDIAN BS 5.5	Steel sheet 0,72mm ⁴⁾	SP 50	1,74	Approved
GUARDIAN BS 6.1	Steel sheet 0,60mm	Sleeve R 45	1,56	Approved
GUARDIAN BS 6.1	Steel sheet 0,70mm	SP 50	1,78	Approved
GUARDIAN BS 6.1	Steel sheet 0,75mm	SP 50	1,98	Approved
GUARDIAN BS 6.1	Steel sheet 1,00mm	SP 50	2,77	Approved
GUARDIAN BS 6.8	Steel sheet 0,50mm	SP 50	1,06	Approved
GUARDIAN BS 6.8	Steel sheet 0,60mm	SP 50	1,31	Approved
GUARDIAN BS 6.8	Steel sheet 0,70mm	SP 50	1,78	Approved
GUARDIAN DBT 4.8	Steel sheet 0,70mm	SPA 8240	1,17	Approved
GUARDIAN DBT 4.8	Steel sheet 0,75mm	SPA 8240	1,41	Approved
GUARDIAN DBT 4.8	Steel sheet 0,80mm	SPA 8240	1,52	Approved
GUARDIAN DBT(A)S 4.8	Steel sheet 0,75mm ⁴⁾	SPA 8240	1,16	Approved
GUARDIAN GPR 6.3	Steel sheet 0,50mm	SP 50	1,19	Approved

³⁾ Steel sheets, galvanized, min S280 according to EN 10147

⁴⁾ Steel sheets, galvanized, yieldstrength 320 MPa

⁵⁾ Obtained value from the axial load test in steel sheets substrates, table 4, and the pullover test, table 6, of washers is compared and the lowest of the two gives the characteristic value for the fastener / sleeve, washer combination of the application.

Table 5: Wood substrate

Fastener	Substrate	Washer	Characteristic values of axial load resistance (kN)
GUARDIAN HD 6.1	18 mm OSB/3 ⁷⁾	-	1,36
GUARDIAN HD 6.1	18 mm multilayer wood deck	-	2,37
GUARDIAN HD 6.1	18 mm wood deck underlayment	-	1,94
GUARDIAN MTS 4.8	18 mm OSB/3 ⁷⁾	SP 50	1,16
GUARDIAN TS 5.2	17mm softwood Class G4-2	SP 50	1,28
GUARDIAN TS 5.2	23mm softwood Class G4-2	SP 50	1,90
GUARDIAN TS 5.2	18 mm OSB/3 ⁷⁾	SP 50	1,35
GUARDIAN TS 5.2	18 mm chipboard	SP 50	1,18
GUARDIAN TS 5.2	18 mm multilayer wood deck	SP 50	1,89
GUARDIAN TS 5.2	18 mm wood deck underlayment	SP 50	1,94
GUARDIAN LBS 6.0	18 mm OSB/3 ⁷⁾	SP 50	1,40
GUARDIAN LBS 6.0	23mm softwood Class G4-2	SP 50	2,00

⁷⁾ OSB board type 3 according to EN 300

Table 6: Pullover test of washer

Washer	Fastener ⁸⁾ Guardian															Characteristic values of axial load resistance (kN)	Durability ETAG 006 cl. 5.3.7 D.2.3, D.3.1, D.3.2 and cl. 5.3.4 D.2.2	
	ACS 6.1	BS 4.8	BS 5.5	BS 6.1	BS 6.8	BSHD 4.8	BSRF 4.8	CS 6.1	DB(A) 4.8	DBT(A) 4.8	DBT(A)-S 4.8	HD 6.1	LBS 6.0	LBS 8.0	PS 4.8			TS 5.2
SP-40 – D/F/DD/FD	-	X	X	X	X	X	X	X	-	-	-	X	X	-	X	X	3,88	Approved
SP-40-LBS	-	-	-	-	-	-	-	-	-	-	-	-	-	X	-	-	4,29	Approved
SP-50-D, F, S	-	X	X	X	X	X	X	X	-	-	-	X	X	-	X	X	4,83	Approved
SPB-50-S	-	X	X	X	X	X	X	X	-	-	-	X	X	-	X	X	4,83	Approved
SP-70-D, F, S	-	X	X	X	X	X	X	X	-	-	-	X	X	-	X	X	2,88	Approved
SPA 8240-D/F/S	-	X	X	X	X	X	X	X	-	-	-	X	X	-	X	X	5,30	Approved
SPA 8240-D	-	-	-	-	-	-	-	-	X	X	X	-	-	-	-	-	5,00	Approved
STBS	-	X	X	X	X	X	X	X	-	-	-	X	X	-	X	X	3,68	Approved
Sleeve CT – STBT	-	X	X	X	X	X	X	X	-	-	-	X	X	-	X	X	1,78	Approved
GWSP (*)-80-F2E	-	-	X	X	X	-	-	X	-	-	-	-	X	-	-	X	2,48	Approved
Sleeve GWT + GWSP (*)-80-F4E	-	X	X	X	X	X	X	X	-	-	-	X	X	-	X	X	3,17	Approved
Sleeve R 45	-	X	X	X	X	X	X	X	-	-	-	X	X	-	X	X	1,58	Approved
Sleeve RB 48	-	X	X	X	X	X	X	X	-	-	-	X	X	-	X	X	1,58	Approved
Sleeve RBS 50	-	X	X	X	X	X	X	X	-	-	-	X	X	-	X	X	1,58	Approved
Sleeve R 75	-	X	X	X	X	X	X	X	-	-	-	X	X	-	X	X	1,58	Approved
Sleeve TBPP	-	X	X	X	X	X	X	X	-	-	-	X	X	-	X	X	1,58	Approved
TBPA 8040	-	X	X	X	X	X	X	X	-	-	-	X	X	-	X	X	2,52	Approved
PP 45	-	X	X	X	-	X	X	X	-	-	-	-	X	-	X	X	2,50	Approved
Sleeve HR 45	X	-	-	-	-	-	-	-	-	-	-	-	-	-	-	-	1,54	Approved
Sleeve HR 75	X	-	-	-	-	-	-	-	-	-	-	-	-	-	-	-	1,54	Approved

⁸⁾Obtained values from the axial load test in different substrates (table 2 - 5) and the pullover test (table 6) of washers/sleeves are compared and the lowest of the two gives the characteristic value for the fastener / sleeve, washer combination of the application.