

SLW110 Maxi Raft Self Levelling Pedestal

Product Information:

SLW110 Series Pedestal Supports are used to construct raised floors at varying heights from 85 mm up to 660 mm and more. These modular supports are used in joist framing and installations with decking or composite flooring materials. Thanks to 'self levelling modul', provides auto correction on sloped surfaces maximum up to 5% gradient.

Features:

Raw material	Polypropylene
Height range	Min. 85 mm - Max. 660 mm
Base diameter	187 mm
Base wall thickness	3 mm
Head diameter	126 mm
Laying surface of base	302 cm ²
Slope correction	% 5
Environmental impact assessment	Eco - Friendly

Application Areas:

Can be used for all indoor and outdoor areas. Also, on levelled surfaces, epoxy or membrane insulated areas.

Application:

Use of any fixing material is not necessary. Optionally, the modules can be fixed to the application surface using adhesive or screw.



Raw Material:

Carrier	Polypropylene
Product Code	240 KTPH
Product Colour	Black
Filler	Calcium Carbonate (CaCO ₃)

SLW110 Technical Drawing:

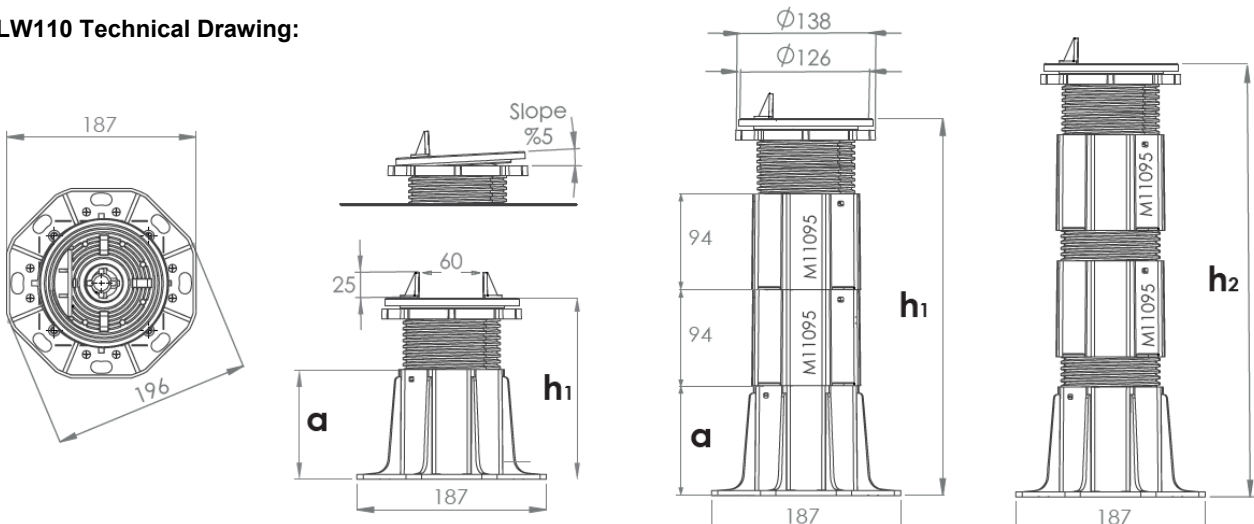

SLW110 Dimension & Weight:

Model	SLW110-04	SLW110-05	SLW110-06	SLW110-07	SLW110-08	SLW110-09	SLW110-10	SLW110-11	SLW110-12	SLW110-13
a	65 mm	109 mm	65 mm	109 mm	65 mm	109 mm	65 mm	109 mm	65 mm	109 mm
h1(min.- max)	85-135 mm	130-180 mm	180-228 mm	224-272 mm	273-322 mm	317-366 mm	367-415 mm	410-460 mm	460-510 mm	505-553 mm
h2	-	-	255 mm	300 mm	377 mm	420 mm	497 mm	540 mm	617 mm	660 mm
Extension	-	-	M11095	M11095	M11095	M11095	M11095	M11095	M11095	M11095
Weight	0,414 gr	0,486 gr	-	-	-	-	-	-	-	-
Comp.			 x1	 x1	 x2	 x2	 x3	 x3	 x4	 x4

Not: SLW110-06-08-10-12 is constituted of SLW110-04 body and screw.
SLW110-07-09-11-13 is constituted of SLW110-05 body and screw.

SLW110 Pressure Resistance:

Pressure measuring point

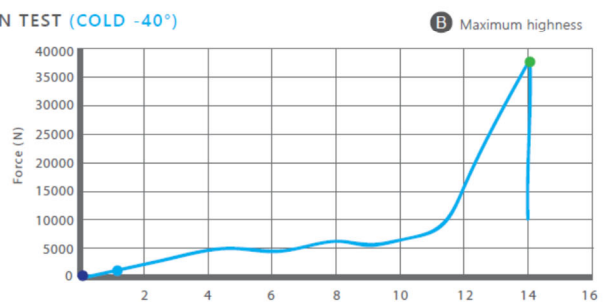
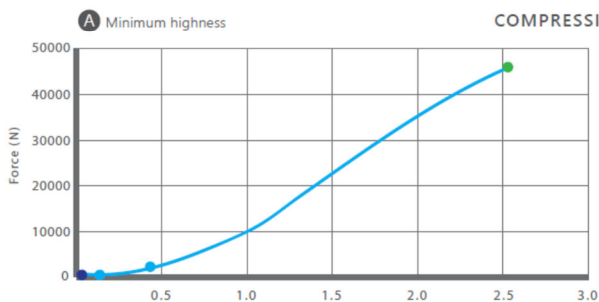
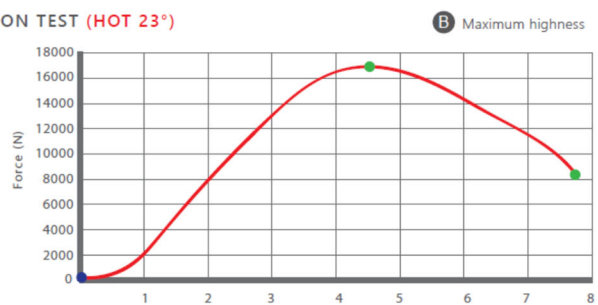
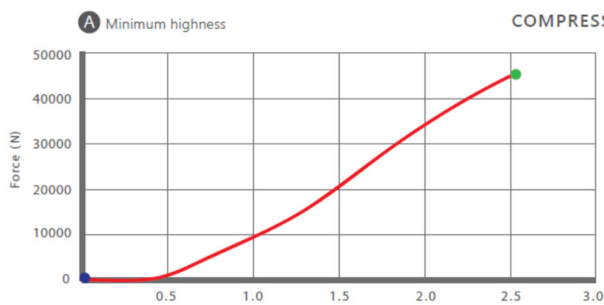
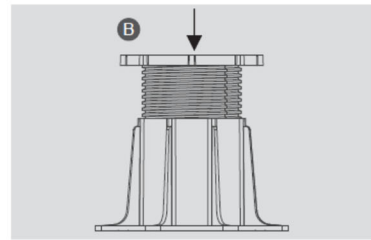
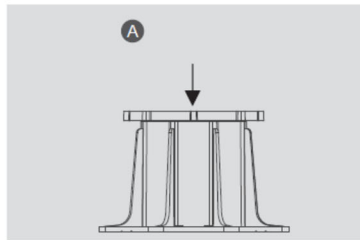

TESTED AND APPROVED BY HEADSHIP OF TURKISH STANDARDS INSTITUTION (TSE) AND CALIBRATION CENTER CONSTRUCTION MATERIALS LABORATORY (ANKARA CITY)

SLW110 Packaging Information:

Product code	SLW110-04	SLW110-05	SLW110-06	SLW110-07	M11095
Pcs per box	24*	20*	16*	14*	24**
Gross weight per box	11,40 kg	11,45 kg	11,80 kg	11,25 kg	5,40 kg
Boxes per pallet	12	12	12	12	24
Box dimensions	60cm x 40cm [*] x h=40cm		40cm x 30cm ^{**} x h=41cm		40cm x 30cm ^{***} x h=20cm
Gross weight per pallet	162 kg	162 kg	167 kg	160 kg	155 kg
Pallet dimensions	cm 80 x 120 x h140				

* Products are packed in cardboard boxes. Shrink-wrapped euro-pallets are used for final packaging. In spite of being shrink-wrapped and rain proof packaging, it is recommended to keep the pallets in a closed area.

* The technical data products above indicate the current production. It may be updated or modified at any time without prior notice.

* We do not take any responsibility for any problem caused by misuse of the products.

Equus Industries Ltd
PO Box 601
Blenheim
Phone: 03 578 0214
Email: admin@equus.nz
Web: www.equus.nz
July 2023