

SL110 Maxi Self Levelling Pedestal

Product Information:

SL110 Series Pedestal Supports designed to construct raised floors at varying heights from 85 mm up to 660 mm and more. Used in tiling/paving applications with natural stone, ceramic and composite flooring materials. Thanks to 'self levelling modul', I110 Series Supports allow auto correction on sloped surfaces maximum up to 5% gradient.

Features:

Raw material	Polypropylene
Height range	Adjustable min. 85 mm - max. 660 mm
Base diameter	187 mm
Base wall thickness	3 mm
Head diameter	126 mm
Laying surface of base	302 cm ²
Tab thickness	2 mm / 3 mm / 4 mm (removable)
Tab height	10 mm
Slope correction	% 5
Environmental impact assessment	Eco - Friendly

Application Areas:

Can be used for all indoor and outdoor areas. Also, on levelled surfaces, epoxy or membrane insulated areas.

Application:

Use of any fixing material is not necessary. Optionally, the modules can be fixed to the application surface using adhesive or screw.



Raw Material:

Carrier	Polypropylene
Product Code	240 KTPH
Product Colour	Black
Filler	Calcium Carbonate (CaCO ₃)

SL110 Technical Drawing:

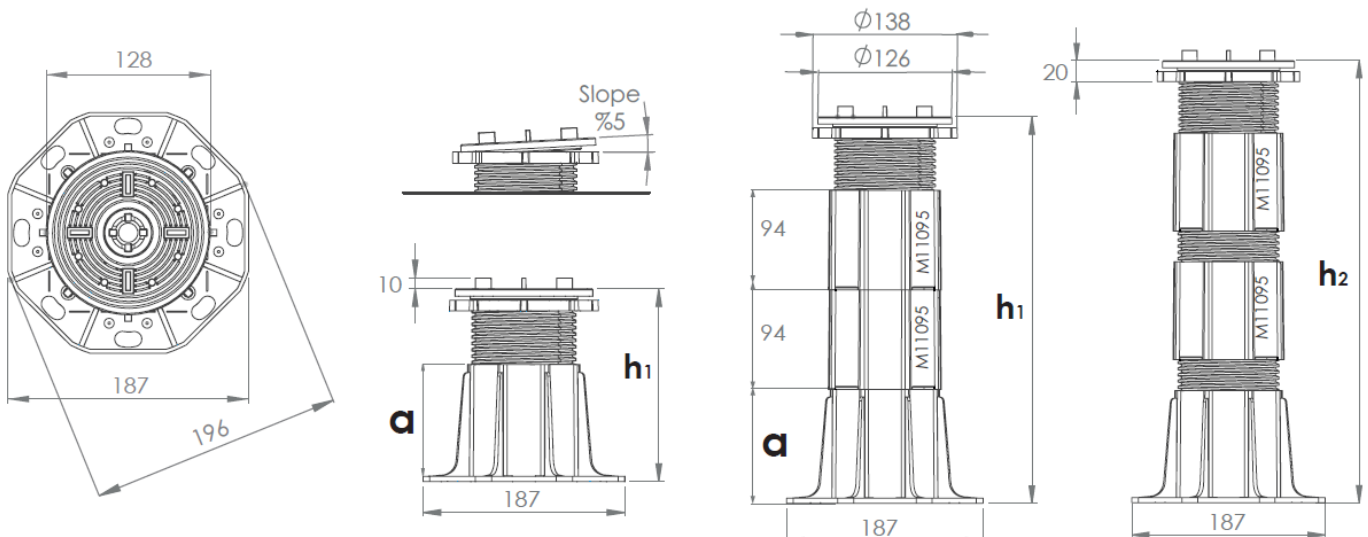

SL110 Dimension & Weight:

Model	SL110-04	SL110-05	SL110-06	SL110-07	SL110-08	SL110-09	SL110-10	SL110-11	SL110-12	SL110-13
a	65 mm	109 mm	65 mm	109 mm	65 mm	109 mm	65 mm	109 mm	65 mm	109 mm
h1(min.- max)	85-135 mm	130-180 mm	180-228 mm	224-272 mm	273-322 mm	317-366 mm	367-415 mm	410-460 mm	460-510 mm	505-553 mm
h2	-	-	255 mm	300 mm	377 mm	420 mm	497 mm	540 mm	617 mm	660 mm
Extension	-	-	M11095	M11095	M11095	M11095	M11095	M11095	M11095	M11095
Weight	0,409 gr	0,481 gr	-	-	-	-	-	-	-	-
Comp.			 x1	 x1	 x2	 x2	 x3	 x3	 x4	 x4

SL110 Pressure Resistance:

Pressure measuring point

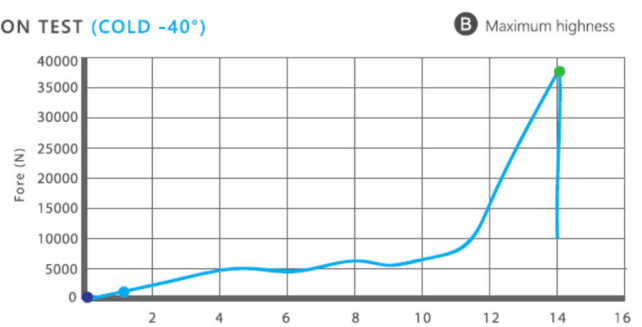
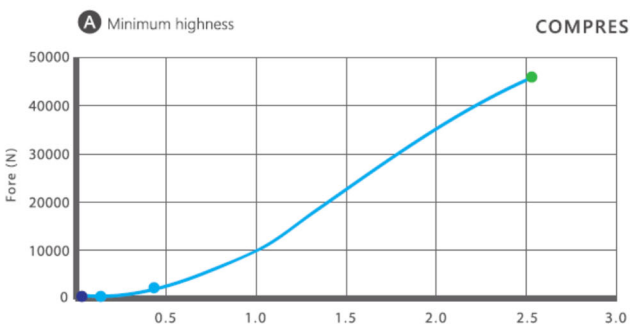
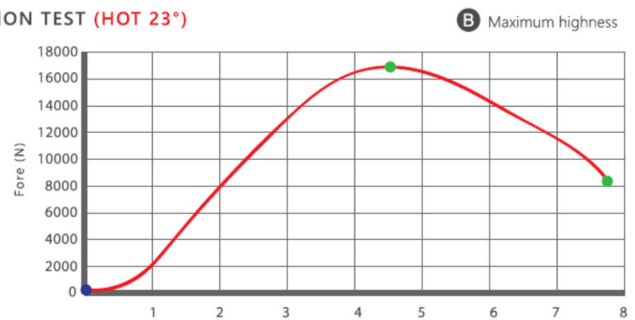
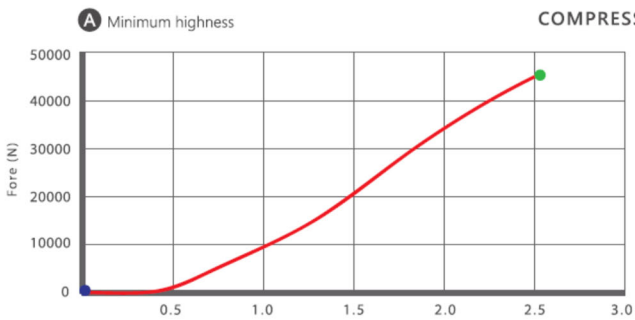
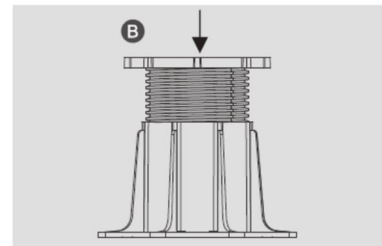
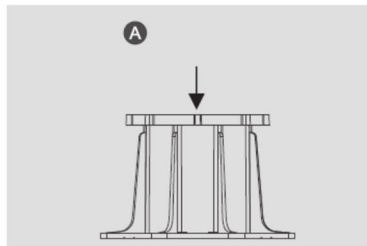

TESTED AND APPROVED BY HEADSHIP OF TURKISH STANDARDS INSTITUTION (TSE) AND CALIBRATION CENTER CONSTRUCTION MATERIALS LABORATORY (ANKARA CITY)

SL110 Packaging Information:

Product code	SL110-04	SL110-05	SL110-06	SL110-07	M11095
Pcs per box	24*	20*	16*	14*	24**
Gross weight per box	11,25 kg	10,65 kg	11,15 kg	10,70 kg	5,40 kg
Boxes per pallet	12	12	12	12	24
Box dimensions	60cm x 40cm [*] x h=40cm	40cm x 30cm ^{**} x h=41cm	40cm x 30cm ^{***} x h=20cm		
Gross weight per pallet	160 kg	153 kg	159 kg	153 kg	155 kg
Pallet dimensions	cm 80 x 120 x h140				

* Products are packed in cardboard boxes. Shrink-wrapped euro-pallets are used for final packaging. In spite of being shrink-wrapped and rain proof packaging, it is recommended to keep the pallets in a closed area.

* The technical data products above indicate the current production. It may be updated or modified at any time without prior notice.

* We do not take any responsibility for any problem caused by misuse of the products.

Equus Industries Ltd
PO Box 601
Blenheim
Phone: 03 578 0214
Email: admin@equus.nz
Web: www.equus.nz
July 2023