

# SL60 Basic Self Levelling Pedestal

## Product Information:

Modules are used with self-levelling system in tile applications to create raised floors. Allow auto slope correction on surfaces maximum up to 5% gradient.

## Features:

Raw material	Polypropylene
Height range	Adjustable min.42 mm - max. 260 mm (Optionally, extra 'extension' can be used to increase the height more than 260 mm)
Base diameter	187 mm
Base wall thickness	3 mm
Head diameter	126 mm
Laying surface of base	302 cm <sup>2</sup>
Tab thickness	2 mm / 3 mm / 4 mm (removable)
Tab height	10 mm
Slope correction	% 5
Environmental impact assessment	Eco - Friendly

## Application Areas:

Can be used for all indoor and outdoor areas. Also, on levelled surfaces, epoxy or membrane insulated areas.

## Application:

Use of any fixing material is not necessary. Optionally, the modules can be fixed to the application surface using adhesive or screw.

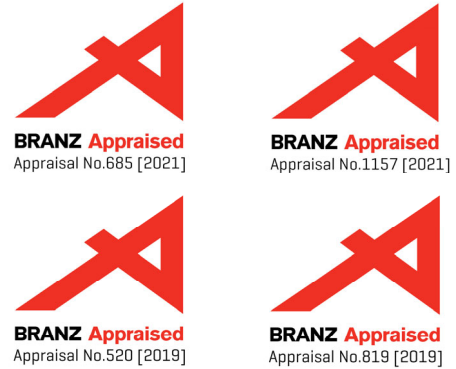

## SL60 Raw Material:

Carrier	Polypropylene
Product Code	240KTPH
Product Colour	Black
Filler	Calcium Carbonate (CaCO <sub>3</sub> )

## SL60 Technical Drawing:

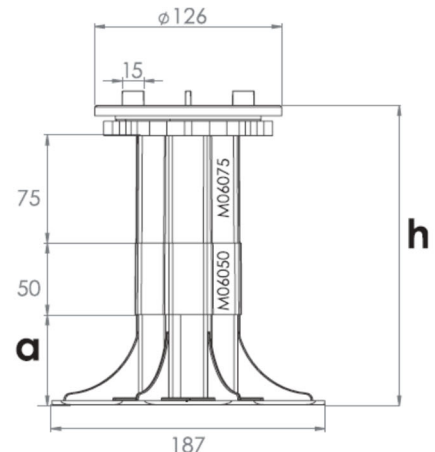
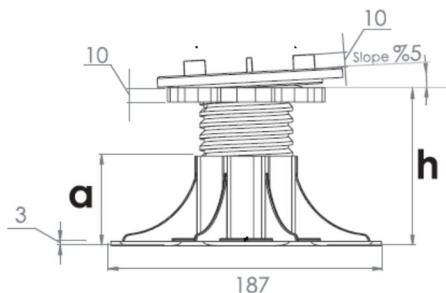
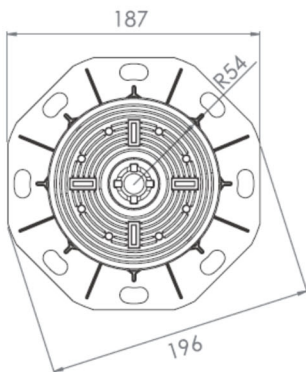

**SL60 Dimension & Weight:**

Model	SL60-01	SL60-02	SL60-03	SL60-04	SL60-05	SL60-06	SL60-07	SL60-08	SL60-09	SL60-10
<b>a</b>	18 mm	27 mm	40 mm	62 mm	40 mm	62 mm	62 mm	62 mm	62 mm	62 mm
<b>h (min. - max)</b>	42-48 mm	48-60 mm	60-85 mm	83-120 mm	112-140 mm	136-165 mm	157-194 mm	185-215 mm	210-235 mm	230-260 mm
<b>Extension</b>	-	-	-	-	M06050	M06050	M06075	M06050	M06050 M06075	M06075
<b>Weight</b>	0,243 kg	0,254 kg	0,271 kg	0,305 kg	-	-	-	-	-	-
<b>Comp.</b>										

**SL60 Pressure Resistance:**

Pressure measuring point

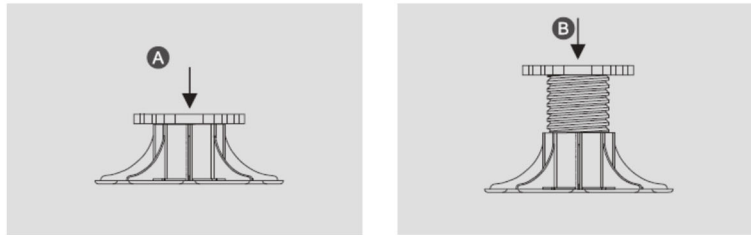

**A** Minimum highness

**COMPRESSION TEST (HOT 23°)**

**B** Maximum highness

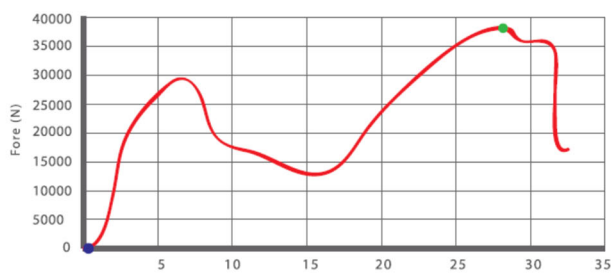
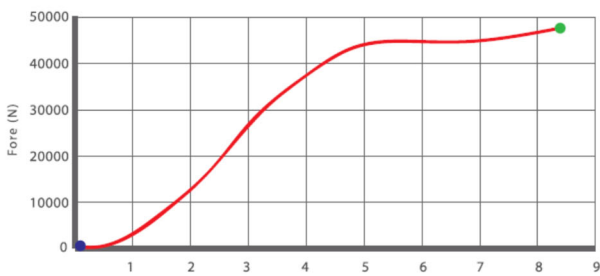

**A** Minimum highness

**COMPRESSION TEST (COLD -40°)**

**B** Maximum highness

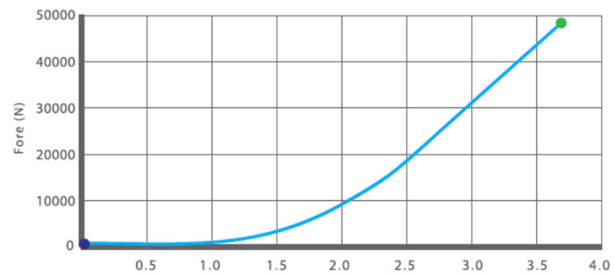
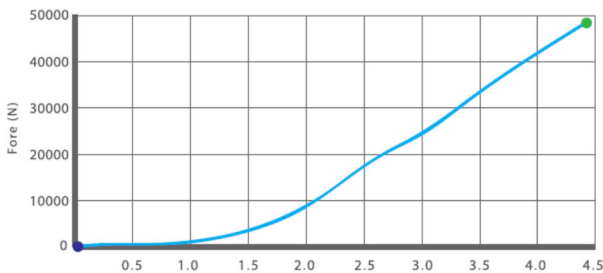

TESTED AND APPROVED BY HEADSHIP OF TURKISH STANDARDS INSTITUTION (TSE) AND CALIBRATION CENTER CONSTRUCTION MATERIALS LABORATORY (ANKARA CITY)

**SL60 Packaging Information:**

Product code	SL60-01	SL60-02	SL60-03	SL60-04	M06050	M06075
Pcs per box	70*	60*	45*	35*	60***	40***
Gross weight per box	18,50 kg	16,65 kg	13,60 kg	12,10 kg	5,40 kg	4,00 kg
Boxes per pallet	12	12	12	12	48	48
Box dimensions	60cm x 40cm x h=40cm <sup>*</sup>		40cm x 30cm x h=41cm <sup>**</sup>		40cm x 30cm x h=20cm <sup>***</sup>	
Gross weight per pallet	247 kg	225 kg	189 kg	170 kg	285 kg	217 kg
Pallet dimensions	cm 80 x 120 x h140					

\* Products are packed in cardboard boxes. Shrink-wrapped euro-pallets are used for final packaging. In spite of being shrink-wrapped and rain proof packaging, it is recommended to keep the pallets in a closed area.

\* The technical data products above indicate the current production. It may be updated or modified at any time without prior notice.

\* We do not take any responsibility for any problem caused by misuse of the products.

**Equus Industries Ltd**  
**PO Box 601**  
**Blenheim**  
**Phone: 03 578 0214**  
**Email: admin@equus.nz**  
**Web: www.equus.nz**  
**July 2023**